

# EASY ACCESS FAN/COIL UNIT FILTER BASE

“Make It E-Z For Your Customer”

- Lift Access Door - Remove Filter
- No Panels Or Door To Remove
- Use Standard Size Filters
- Keep Evaporator Coils Clean
- More Efficient - Heating & Cooling
- Customized Professional Installations
- Creates Customer Referrals
- Accepts 1” or 2” Filters

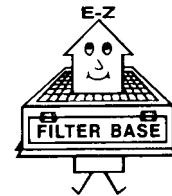
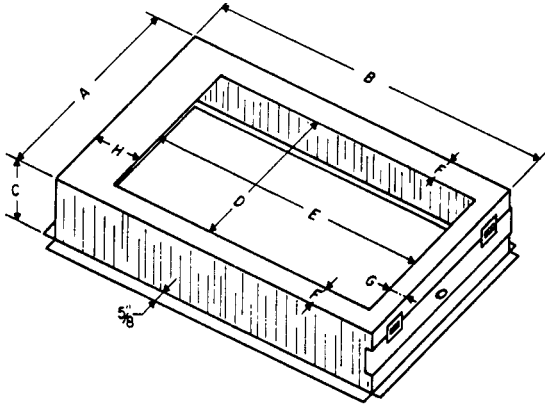

## Air Handlers And Filter Base Required

MODEL NUMBER	FILTER BASE REQUIRED	MODEL NUMBER	FILTER BASE REQUIRED	MODEL NUMBER	FILTER BASE REQUIRED
EBP1800	EZ-1420-FC	EBP4200	EZ-2020-FC	EBX2400	EZ-1620-FC
EBP2400	EZ-1420-FC	EBP4800	EZ-2020-FC	EBX3600	EZ-2020-FC
EBP3000	EZ-1620-FC	EBP6000	EZ-2020-FC	EBX4800	EZ-2020-FC
EBP3600	EZ-1620-FC	EBX1800	EZ-1620-FC	EBX6000	EZ-2025-FCW

## Physical Data And Specifications

MODEL NUMBER	OVERALL			OPENING		TOP			GAUGE METAL	APPROX. WEIGHT	FILTER SIZE*
	A	B	C	D	E	F	G	H			
EZ-1620-FC	17 1/2	22	4	15	19	1 1/4	1	2	22	6 LBS.	16 X 20
EZ-2020-FC	21	22	4	18 1/2	19	1 1/4	1	2	22	6 1/2 LBS.	20 X 20
EZ-2025-FCW	25	22	4	22 1/2	19	1 1/4	1	2	22	7 LBS.	20 X 25
EZ-2719-FC	27 1/2	22	4	25	19	1 1/4	1	1 1/2	22	8 LBS.	19 X 27

NOTE: \*Accepts 1” Or 2” Filter  
 FILTER NOT INCLUDED  
 Suitable For Use With Disposable Or  
 Electrostatic Type Washable Filters

U.S. Patent No. 4,827,901  
 U.S. Patent No. 4,919,123

**E-Z FILTER BASE MFG., INC.**

P.O. Box 180854 - DALLAS, TEXAS 75218-0954